

LONG TERM EVOLUTION: NEXT GENERATION NETWORK.

Aditi Somendra Biswas

Shri Sant Gadge Baba College of Engineering and Technology, ZTC, Bhusawal. Dist:- Jalgaon,
Corresponding author: aditibiswas.329@gmail.com

ABSTRACT

The 3GPP Long Term Evolution (LTE) represents a major advance in cellular technology. LTE is designed to meet carrier needs for high-speed data and media transport as well as high-capacity voice support well into the next decade. It encompasses high-speed data, multimedia unicast and multimedia broadcast services. The LTE PHY is a highly efficient means of conveying both data and control information between an enhanced base station (eNodeB) and mobile user equipment (UE).

Keywords: OFDMA, SC-FDMA, MIMO and SAE.

INTRODUCTION

Third generation (3G) phones use digital communications, but they send and receive their signals in a very different way from their predecessors. This allows them to support much higher data rates than before, and hence to provide more demanding services such as video calls and high speed Internet access. Third-generation (3G) wireless systems, based on wideband code-division multiple access (WCDMA) radio access technology, are now being deployed on a broad scale all over the world. The first step in the evolution of WCDMA has also been taken by the Third Generation Partnership Project (3GPP) through the introduction of high-speed downlink packet access (HSDPA) and enhanced uplink (Fig1). These technologies provide 3GPP with a radio access technology that will be highly competitive in the mid-term future.

EVOLVED SYSTEM ARCHITECTURE

This section presents technical solutions for the evolved radio access and RAN. A top-down approach is followed, beginning with architecture aspects and ending with physical layer issues.

Architecture Evolution: Based on the requirements of reduced latency and cost, it is natural to consider system architectures that contain a reduced number of network nodes along the data path. This would reduce both the overall protocol-related processing as well as the number of interfaces, which in turn reduces the cost of interoperability testing. A reduction of the number of nodes also makes it possible to reduce call setup times, as fewer nodes will be involved in the call setup procedure. Such a reduction also gives greater possibilities to merge control plane protocols, thereby potentially further reducing call setup times. Fig.2 illustrates the current Rel-6 architecture and a possible path for an architecture evolution. In Rel-6, the Node B handles the lower layers of the wireless access, as this is the node with the antenna. The radio network controller (RNC) handles radio resource management, mobility management (locally), call control, and transport network optimization (Astely, 2006).

It further acts as a termination point for the radio protocols. The gateway General Packet Radio Service (GPRS) support node (GGSN) acts as an anchor node in the home network. The serving GPRS support node (SGSN) acts as an anchor node in the visiting network and handles both mobility management and session management. Typically all traffic is routed back to the home network so that a consistent service environment can be maintained while also allowing the operator to filter traffic and provide security to the end user (e.g., by means of firewalls).

In the proposed LTE architecture, the Rel-6 nodes GGSN, SGSN, and RNC are merged into a single central node, the access core gateway (ACGW) as shown in Fig. 2. The ACGW terminates the control and user planes for the user equipment (UE), and handles the core network functions provided by the GGSN and SGSN in Rel-6. The control plane protocol for the UE will be similar to radio resource control (RRC) in Rel-6, for example handling control of mobility and radio bearer configuration.

In the user plane the ACGW will handle functions like header compression, ciphering, integrity protection, and automatic repeat request (ARQ).

The proposed architecture has the following merits:

1. User-plane latency is reduced, as there are fewer nodes, and less protocol packing/ unpacking.
2. Call/bearer setup time is reduced, as there are fewer nodes involved in the setup procedure.
3. Complexity is reduced, as there are fewer interfaces to implement and test. The amount of interoperability testing required will therefore also be reduced.
4. Placing an ARQ protocol in the ACGW will provide both robustness against lower-layer losses and a simple way to provide lossless mobility.
5. Performing ciphering and integrity protection of control and user plane data in the ACGW allows for a security solution at least as strong as in Rel-6.

OFDMA is employed as the multiplexing scheme in the LTE downlink (Fig 3). Perhaps the best way to

describe OFDMA is by contrasting it with a packet-oriented networking scheme such as 802.11a. In 802.11a, Carrier-Sense Multiple Access (CSMA) is the multiplexing method. Downlink and uplink traffic from the fixed access point (AP) to mobile user stations (STAs) is by means of PHY layer packets

OFDMA: Downlink and uplink traffic from the fixed access point (AP) to mobile user stations (STAs) is by means of PHY layer packets. OFDMA makes much more efficient use of network resources.

Comparison of OFDMA with Packet-Oriented

Protocols: Like 3GPP LTE, IEEE 802.11a uses OFDM as the underlying modulation method. However, 802.11a uses CSMA as the multiplexing method. CSMA is essentially a listen-before-talk scheme. For example, when the AP has queued traffic for a STA, it monitors the channel for activity. When the channel becomes idle, it begins to decrement an internal timer that is randomized within a specified window. The timer will continue to be decremented as long as the network remains idle. When the timer reaches zero, the AP will transmit a PHY layer packet of up to 2000 bytes addressed to a particular STA (or all STAs within the cell in the case of broadcast mode) (Fig 4). The randomized back-off period is designed to minimize collisions, but it cannot eliminate them entirely (Mino Diaz, 2004).

Each 802.11a PHY packet utilizes all of the PHY layer bandwidth for the duration of the packet. Consider the 802.11a PHY packet format shown in Fig.5. Each 802.11a packet has a data payload of varying length from 64 to 2048 bytes. If the packet transmission is successful, the receiving station transmits an ACK. Unacknowledged packets are assumed to be dropped. Note that each packet is preceded by a PHY preamble which is 20 μ sec in duration. The purposes of the PHY preamble are:

1. Signal detection
2. Antenna diversity selection
3. Setting AGC
4. Frequency offset estimation
5. Timing synchronization
6. Channel estimation

The address of the intended recipient is not in the PHY preamble. It is actually in the packet data and is interpreted at the MAC layer. From a networking perspective, the packet-oriented approach of 802.11a has the advantage of simplicity. Each packet is addressed to a single recipient (broadcast mode notwithstanding). However, the randomized backoff period of the CSMA multiplexing scheme is idle time and therefore represents an inefficiency. The PHY preamble is also network overhead and further reduces efficiency, particularly for shorter packets.

OFDMA and the LTE Generic Frame Structure:

OFDMA is an excellent choice of multiplexing scheme for the 3GPP LTE downlink. Although it involves added complexity in terms of resource scheduling, it is vastly superior to packet-oriented approaches in terms of efficiency and latency. In OFDMA, users are allocated a specific number of subcarriers for a predetermined amount of time. These are referred to as physical resource blocks (PRBs) in the LTE specifications. PRBs thus have both a time and frequency dimension. Allocation of PRBs is handled by a scheduling function at the 3GPP base station (eNodeB) (Fig 5).

As shown in Fig.6, LTE frames are 10 msec in duration. They are divided into 10 subframes, each subframe being 1.0 msec long. Each subframe is further divided into two slots, each of 0.5 msec duration. Slots consist of either 6 or 7 OFDM symbols, depending on whether the normal or extended cyclic prefix is employed. The total number of available subcarriers depends on the overall transmission bandwidth of the system. The LTE specifications define parameters for system bandwidths from 1.25 MHz to 20 MHz as shown in Table 1. A PRB is defined as consisting of 12 consecutive subcarriers for one slot (0.5 msec) in duration. A PRB is the smallest element of resource allocation assigned by the base station scheduler (Parkvall *et al.*, 2001).

The transmitted downlink signal consists of NBW subcarriers for a duration of N_{symb} OFDM symbols. It can be represented by a resource grid as depicted in Fig.7. Each box within the grid represents a single subcarrier for one symbol period and is referred to as a resource element. In contrast to packet-oriented networks, LTE does not employ a PHY preamble to facilitate carrier offset estimate, channel estimation, timing synchronization etc. Instead, special reference signals are embedded in the PRBs as shown in Fig.8. Reference signals are transmitted during the first and fifth OFDM symbols of each slot when the short CP is used and during the first and fourth OFDM symbols when the long CP is used. The LTE PHY can optionally exploit multiple transceivers at both the base station and UE in order to enhance link robustness and increase data rates for the LTE downlink. In particular, maximal ratio combining (MRC) is used to enhance link reliability in challenging propagating conditions when signal strength is low and multipath conditions are challenging. MIMO is a related technique that is used to increase system data rates. In MIMO applications, there is a resource grid for each transmitting antenna.

Fig.9 shows a conventional single channel receiver with antenna diversity. This receiver structure uses multiple antennas, but it is not capable of supporting MRC/MIMO. The basic receiver topology

for both MRC and MIMO is shown in Fig.9. MRC and MIMO are sometimes referred to as “multiple antenna” technologies, but this is a bit of a misnomer. Note that the salient difference between the receivers shown in Fig.9 and is not multiple antennas, but rather multiple transceivers. With MRC, a signal is received via two (or more) separate antenna/transceiver pairs. Note that the antennas are physically separated, and therefore have distinct channel impulse responses. Channel compensation is applied to each received signal within the baseband processor before being linearly combined to create a single composite received signal. When combined in this manner, the received signals add coherently within the baseband processor. However, the thermal noise from each transceiver is uncorrelated. Thus, linear combination of the channel compensated signals at the baseband processor results in an increase in SNR of 3 dB on average for a two-channel MRC receiver in a noise limited environment (Parkvall *et al.*, 2005).

Aside from the improvement in SNR due to combining, MRC receivers are robust in the presence of frequency selective fading. Recall that physical separation of the receiver antennas results in distinct channel impulse responses for each receiver channel. In the presence of frequency selective fading, it is statistically unlikely that a given subcarrier will undergo deep fading on both receiver the composite signal is therefore significantly reduced. MRC enhances link reliability, but it does not increase the nominal system data rate. In MRC mode, data is transmitted by a single antenna and is processed at the receiver via two or more receivers. MRC is therefore a form of receiver diversity rather than more conventional antenna diversity. MIMO, on the other hand, does increase system data rates. This is achieved by using multiple antennas on both the transmitting and receiving ends (fig 9).

In order to successfully receive a MIMO transmission, the receiver must determine the channel impulse response from each transmitting antenna (Fig. 10). In LTE, channel impulse responses are determined by sequentially transmitting known reference signals from each transmitting antenna as shown in Fig.11. Referring to the 2 x 2 MIMO system in Fig.12, there are a total of four channel impulse responses (C1, C2, C3 and C4). Note that while one transmitter antenna is sending the reference signal, the other antenna is idle. Once the channel impulse responses are known, data can be transmitted from both antennas simultaneously. The linear combination of the two data streams at the two receiver antennas results in a set of two equations and two unknowns, which is resolvable into the two original data streams.

SC-FDMA: LTE uplink requirements differ from downlink requirements in several ways. Not surprisingly, power consumption is a key consideration for UE terminals. The high PAPR and related loss of efficiency associated with OFDM signaling are major concerns. As a result, an alternative to OFDM was sought for use in the LTE uplink. Single Carrier – Frequency Domain Multiple Access (SC-FDMA) is well suited to the LTE uplink requirements. The basic transmitter and receiver architecture is very similar (nearly identical) to OFDMA, and it offers the same degree of multipath protection. Importantly, because the underlying waveform is essentially single-carrier, the PAPR is lower.

The block diagram of Fig.13 shows a basic SC-FDMA transmitter / receiver arrangement. Note that many of the functional blocks are common to both SC-FDMA and OFDMA, thus there is a significant degree of functional commonality between the uplink and downlink signal chains. In the receive side chain, the process is essentially reversed. As in the case of OFDM, SC-FDMA transmissions can be thought of as linear summations of discrete subcarriers. Multipath distortion is handled in the same manner as in OFDM systems (removal of CP, conversion to the frequency domain, then apply the channel correction on a subcarrier-by subcarrier basis). Unlike OFDM, the underlying SC-FDMA signal represented by the discrete subcarriers is— not surprisingly—single carrier. This is distinctly different than OFDM because the SC-FDMA subcarriers are not independently modulated. As a result, PAPR is lower than for OFDM transmissions. Analysis has shown that the LTE UE RPA can be operated about 2 dB closer to the 1-dB compression point than would otherwise be possible if OFDM were employed on the uplink (Xiao *et al.*, 2005).

As mentioned above, SC-FDMA subcarriers can be mapped in one of two ways: localized or distributed as shown in Fig. 13. However, the current working assumption is that LTE will use localized subcarrier mapping. This decision was motivated by the fact that with localized mapping, it is possible to exploit frequency selective gain via channel dependent scheduling (assigning uplink frequencies to UE based on favorable propagation conditions).

ADVANCED ANTENNA TECHNOLOGIES

To achieve high data rates, high capacity and extended coverage, LTE also uses advanced antenna solutions, such as MIMO and beamforming. MIMO refers to the use of multiple antennas in wireless communications on both the transmitting and the receiving side. MIMO can be used in different modes, such as spatial multiplexing, transmit diversity and cyclic delay diversity. Spatial multiplexing is the transmission of independent and separately coded data streams in parallel over

non-correlated antennas. The radio channel ideally consists of $N_{Tx} \times N_{Rx}$ non-correlated paths, where N_{Tx} is the number of transmitting and N_{Rx} the number of receiving antennas. The transmitted streams belong to a single or several users, increasing the link throughput of a single user or the entire capacity on a certain frequency band. The theoretical increase factor of channel throughput is $\min(N_{Tx}, N_{Rx})$ in environments with large signal scattering, while there is no gain in environments with direct visibility. The basic MIMO configuration in LTE on the downlink is two antennas on both the transmitting and the receiving side (Xiao *et al.*, 2005).

On the uplink, spatial multiplex changes to SDMA (Spatial Division Multiple Access), where several mobile terminals transmit on the same physical resources simultaneously. The mobile terminals primarily transmit with a single antenna, but transmission with two antennas is also supported. Instead of increasing data rates, MIMO can also be used to increase the robustness of the transmission. This mode is known as transmit diversity and is usually employed when channel conditions do not allow spatial multiplexing. Each antenna transmits the same data stream with different channel coding, which is predefined and referred to as Space-Frequency Block Coding. Cyclic delay diversity can be used in addition to spatial multiplexing. Each antenna transmits with a specific delay that is added to the signal, which creates an additional multipath delay and increases frequency diversity at the receiver. The electromagnetic signal at the transmitting antenna can be formed into a beam, which is known as beamforming. By guiding the beam towards the user, faster transmission rates, control and reduction of interference from other users can be achieved, resulting in higher SNR (Signal to Noise Ratio) at the receiver. While MIMO increases channel throughput in the centre of a cell, beamforming increases channel throughput on the cell edges.

Signal processing on the physical layer: Prior to transmission, the signal is processed to optimally exploit radio channel conditions. The most important procedures are:

1. 24-bit CRC (Cyclic Redundancy Check) coding;
2. channel coding using turbo codes based on QPP (Quadratic Permutation Polynomial) inner interleaving with trellis termination;
3. HARQ (Hybrid Automatic Repeat Request) processing for error detection and correction;
4. QPSK (Quadrature Phase Shift Keying), 16QAM or 64QAM modulation;
5. scheduling based on the target QoS (Quality of Service), signal quality, capabilities of the mobile terminal and the state of the buffer at the base station;
6. Mapping to assigned PRBs and antenna ports.

On the downlink, adaptive modulation and coding with different modulation schemes and bit rates are used, depending mostly on the quality of the received signal at the mobile terminal, which is reported to the network. The same modulation and coding are used for all PRBs that belong to the same PDU (Protocol Data Unit) of the link layer for a single user within a single TTI and data stream (e.g. transmitted from a single antenna).

The upper layers of the LTE Protocol Stack: Fig.15 presents the structure of the link layer for the downlink. The scheme for the uplink is similar. The SAPs (Service Access Points) of the physical layer are known as the transport channels, while those of the MAC (Media Access Control) sublayer are known as logical channels and the SAPs of the link layer are radio bearers. Transport channels correspond to services provided by the physical layer. These services are defined by how and with what characteristics data are transported over the radio interface. Logical channels correspond to the data transfer services that are offered by the MAC sublayer and are defined by the type of information they carry. Logical channels are divided on the control channels that carry data on the control plane and traffic channels that carry the user plane data. Radio bearers correspond to the type of information and quality of service at transmission on the radio interface, e.g. to VoIP, video streaming, file transfer and control plane communications. The MAC sublayer controls access to the physical medium. It performs the mapping among logical and transport channels, and the multiplexing/demultiplexing of these channels. It also performs radio resource allocation, priority handling and HARQ-based error corrections (Parkvall *et al.*, 2001).

The RLC (Radio Link Control) controls links on the radio interface, performs traffic control, segmentation and reassembly of data packets and error correction based on ARQ (Automatic Repeat reQuest). It provides different modes of operation suitable for different radio bearers. The PDCP (Packet Data Convergence Protocol) converts the PDUs of the higher layers into a format suitable for transfer over the radio interface. It provides in-sequence delivery of PDUs and security mechanisms, and performs header compression of network-layer PDUs (Fig 14). The RRC (Radio Resource Protocol) is a network-layer protocol of the control plane that handles signalization. It supports the transmission of broadcast system information and dedicated control information, establishes and maintains services, and controls the QoS.

SAE

SAE (System Architecture Evolution) is a core network architecture that supports the

characteristics of LTE. SAE introduces a packet switched mobile core network EPC (Evolved Packet Core) with the following elements:

1. S-GW (Serving Gateway) and PDN (Packed Data Network) gateway on the user plane
2. MME (Mobility Management Entity) on the control plane.

The elements of EPC can be incorporated into one or more physical nodes, linked with standardized interfaces, which enable the use of hardware of various manufacturers. Fig.15 shows a simplified SAE network architecture.

SAE separates the user and the control plane. The latter is managed especially by the MME. Because there are no radio network controllers, as individual network elements in SAE, the base station (eNB, eNodeB) connects directly with the MME or S-GW for the exchange of user and control information (Fig. 16). Besides routing data towards the EPC, the eNodeB also schedules and transmits paging messages, selects an MME during network attachment, etc. The eNodeB communicates with mobile terminals over link layer protocols and the RRC, and also implements the functionality of the physical layer presented in the previous sections. MME is the key control node in the network. It performs the signalization and controls the entities in various layers of the protocol stack. The Serving Gateway supports mobility anchoring during inter-eNodeB handover and inter-3GPP network mobility. It also supports charging and performs routing, forwarding, buffering, marking and interception of data packets. The PDN Gateway ensures the connectivity of the mobile terminal with other packet data networks. The functions of the PDN Gateway include filtering, intercepting and marking of data packets, DHCP (Dynamic Host

Configuration Protocol), support for charging and traffic shaping (Parkvall *et al.*, 2005).

CONCLUSION

No one can really sure what the future 4G will look like and what services it will offer to people. However, we can get the general idea about 4G from academic research; 4G is the evolution based on 3G's limitation and it will fulfill the idea of WWW, World Wide Wireless Web, offering more services and smooth global roaming with inexpensive cost.

REFERENCES

3GPP, "Requirements for Evolved UTRA (E-UTRA) and Evolved UTRAN (EUTRAN)," Tech. rep. 25.913, <http://www.3gpp.org>.

Astely, D.2006. "A Future-Radio-Access Framework," to appear, *IEEE JSAC*, Special Issue on 4G Wireless Systems.

Mino Diaz, E. 2004. "The WINNER Project: Research for New Radio Interfaces for Better Mobile Services," *IEICE Trans.*, Japan, E87-A (10):2592-2598.

Parkvall, S., Dahlman, E., Frenger, P., Beming, P and M. Persson. 2001."The High Speed Packet Data Evolution of WCDMA," *Proc. IEEE PIMRC 2001*, 2: G27-31.

Parkvall, S., Pesia,J., Torsner, J., Mats, S and P. Malm. 2005. "WCDMA Enhanced Uplink — Principles and Basic Operation," *Proc. VTC Spring 2005*, May. http://www.3g4g.co.uk/Hspa/HSPA_WP_0505_Ericsson.pdf.

Xiao-Hu Yu, Guoan Chen, Ming Chen, and Xiqi Gao. 2005. "Toward beyond 3G: The FUTURE project in China," *IEEE Communications Magazine*, 43(1):70-75.

Fig.1: The current 3GPP Release 6 architecture (left) and one possible evolved 3G architecture reducing the number of nodes along the data path from 4 to 2 (right).

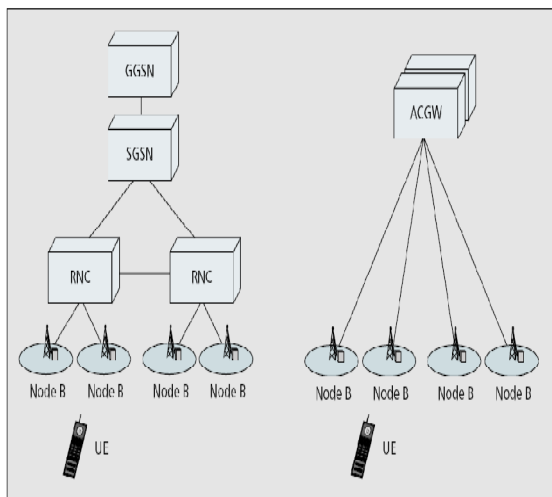

Fig.2: Schematic data flow through the RLC and MAC layer for downlink traffic.

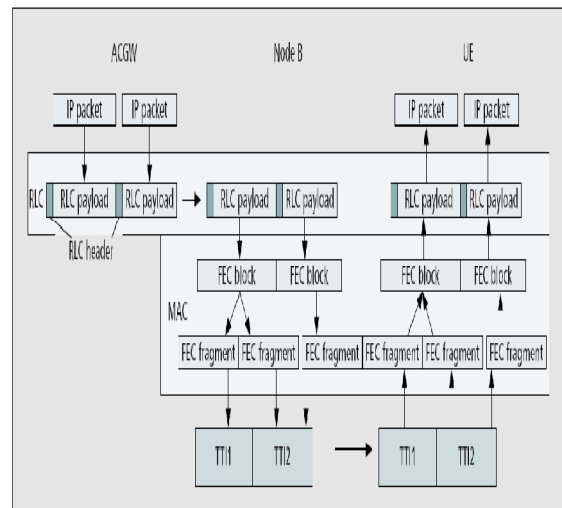

Fig.3: LTE Architecture.

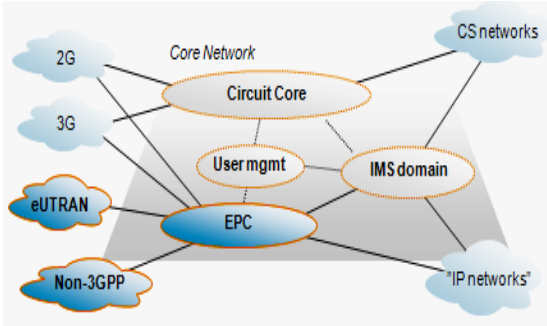

Fig.4: Conventional Packet Oriented Networks Like IEEE 802.11a Precede Each Data Transmission with a PHY Layer Preamble and Header.

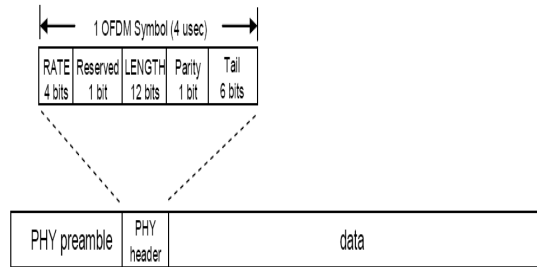

Fig.5: LTE Generic Frame Structure.

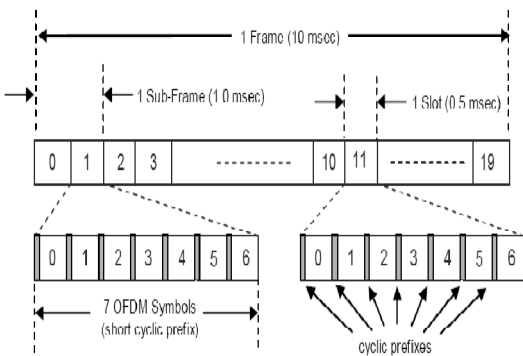

Fig.6: Downlink Resource Grid.

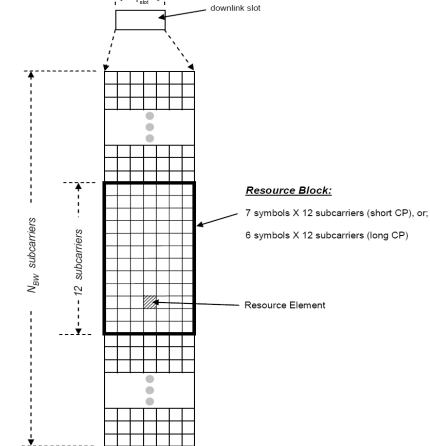

Fig.7: LTE Reference Signals are Interspersed among Resource Elements. MIMO AND MRC

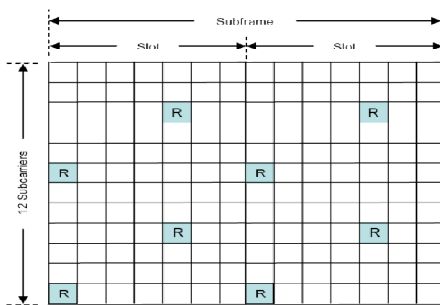

Fig.8: MRC/MIMO Operation Requires Multiple Transceivers.

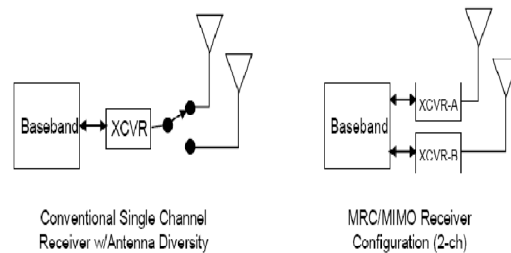

Fig.9: MRC Enhances Reliability in the Presence of AWGN and Frequency Selective Fading.

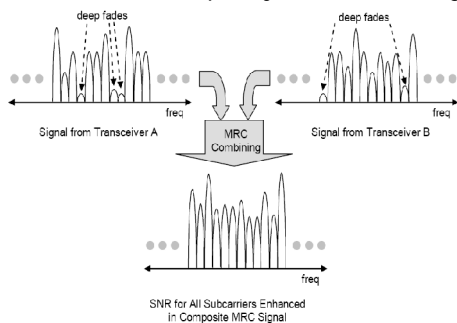

Fig.10: Reference Signals Transmitted Sequentially to Compute Channel Responses for MIMO Operation.

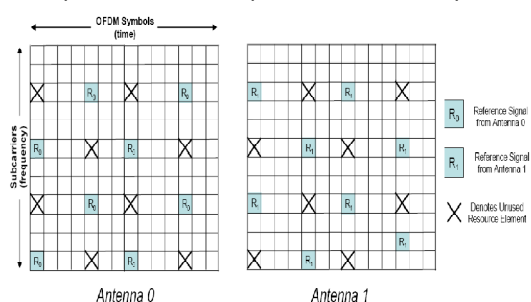

Fig.11: MIMO Operation Requires A priori Knowledge of all Channel Responses.

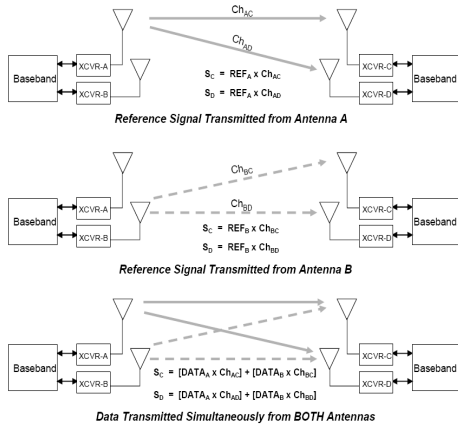

Fig.12: SC-FDMA and OFDMA Signal Chains Have a High Degree of Functional Commonality.

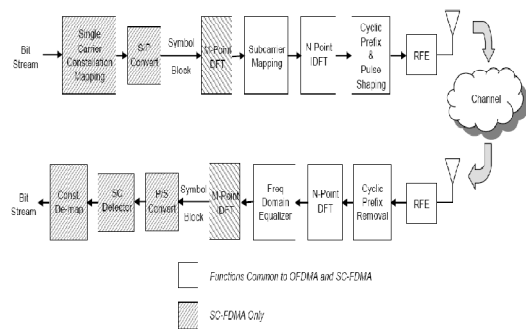

Fig.13: SC-FDMA Subcarriers Can be Mapped in Either Localized or Distributed Mode.

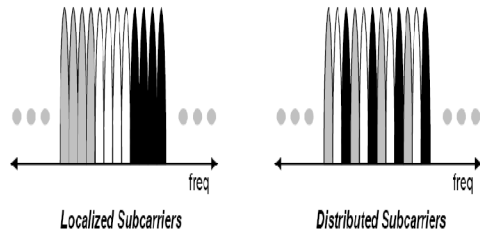

Fig.14: Link layer structure for the downlink

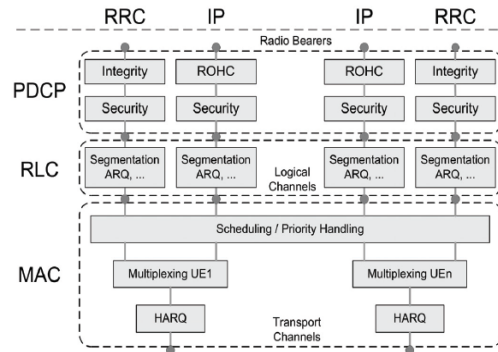

Fig.15: Architecture of LTE radio access (E-UTRAN) and core network (EPC).

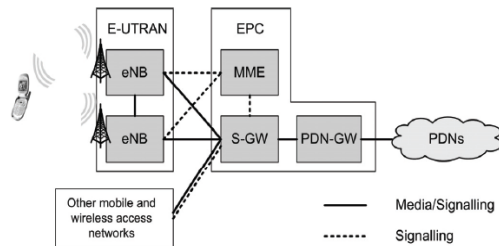

Table 1: Available Downlink Bandwidth is Divided into Physical Resource Blocks.

| Bandwidth MHz | 1.25 | 2.5 | 5.0 | 10.0 | 15.0 | 20.0 |
|---|------|-----|-----|------|------|------|
| Subcarrier Bandwidth (kHz) | 15 | | | | | |
| Physical resource block (PRB) bandwidth (kHz) | 180 | | | | | |
| Number of available PRBs | 6 | 12 | 25 | 50 | 70 | 100 |
